

DESIGN NOTES

New Comparators Feature Micropower Operation Under All Conditions – Design Note 137

Jim Williams

Some micropower comparators have operating modes that allow excessive current drain. In particular, poorly designed devices can conduct large transient currents during switching. Such behavior causes dramatically increased power drain with rising frequency, or when the inputs are nearly balanced, as in battery monitoring applications.

Figure 1 shows a popular micropower comparator's current consumption during switching. Trace A is the input pulse, trace B is the output response and trace C is the supply current. The device, specified for micropower level supply drain, pulls 40mA during switching. This undesirable surprise can upset a design's power budget or interfere with associated circuitry's operation.

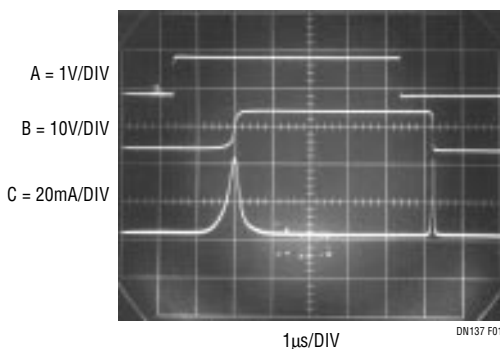

Figure 1. Poorly Designed “Micropower” Comparator Pulls Huge Currents During Transitions. Result Is Excessive Current Consumption with Frequency

The LTC[®]1440 series comparators are true micropower devices. They eliminate current peaking during switching, resulting in greatly reduced power consumption versus frequency, or when the inputs are nearly balanced. Figure 2's plot contrasts the LTC1440's power consumption versus frequency with that of another comparator specified as a micropower component. The LTC1440 has about 200 times lower current consumption at higher frequencies, while maintaining a significant advantage below 1kHz.

Table 1 shows some LTC1440 family characteristics. A voltage reference and programmable hysteresis are included in some versions, with 5µs response time for all devices.

LTC and LT are registered trademarks of Linear Technology Corporation.

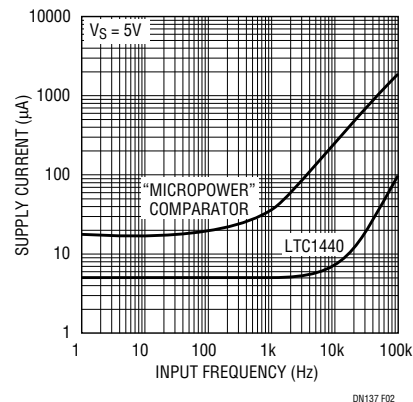

Figure 2. The LTC1440 Family Draws 200 Times Lower Current at Frequency Than Another Comparator

Table 1. Some Characteristics of the LTC1440 Family of Micropower Comparators

PART NUMBER	NUMBER OF COMPARATORS	REFERENCE	PROGRAMMABLE HYSTERESIS	PACKAGE	PROP. DELAY (100mV OVERDRIVE)	SUPPLY RANGE	SUPPLY CURRENT
LTC1440	1	1.182V	Yes	8-Lead PDIP, SO	5µs	2V to 11V	4.7µA
LTC1441	2	No	No	8-Lead PDIP, SO	5µs	2V to 11V	5.7µA
LTC1442	2	1.182V	Yes	8-Lead PDIP, SO	5µs	2V to 11V	5.7µA
LTC1443	4	1.182V	No	16-Lead PDIP, SO	5µs	2V to 11V	8.5µA
LTC1444	4	1.221V	Yes	16-Lead PDIP, SO	5µs	2V to 11V	8.5µA
LTC1445	4	1.221V	Yes	16-Lead PDIP, SO	5µs	2V to 11V	8.5µA

The new devices permit high performance circuitry with low power drain. Figure 3's quartz oscillator, using a standard 32.768kHz crystal, starts under all conditions with no spurious modes. Current drain is only 9 μ A at a 2V supply.

Figure 4's voltage-to-frequency converter takes full advantage of the LTC1441's low power consumption under dynamic conditions. A 0V to 5V input produces a 0Hz to 10kHz output, with 0.02% linearity, 60ppm/ $^{\circ}$ C drift and 40ppm/V supply rejection. Maximum current consump-

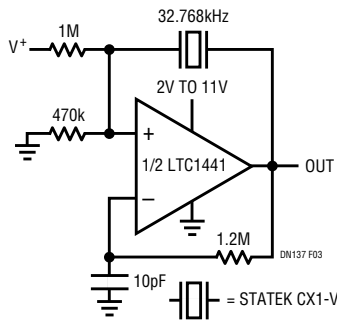

Figure 3. 32.768kHz "Watch Crystal" Oscillator Has No Spurious Modes. Circuit Pulls 9 μ A at $V_S = 2V$

tion is only 26 μ A, 100 times lower than currently available circuits. C1 switches a charge pump, comprising Q5, Q6 and the 100pF capacitor, to maintain its negative input at 0V. The LT1004s and associated components form a temperature-compensated reference for the charge pump. The 100pF capacitor charges to a fixed voltage; hence, the repetition rate is the circuit's only degree of freedom to maintain feedback. Comparator C1 pumps uniform packets of charge to its negative input at a repetition rate precisely proportional to the input voltage derived current. This action ensures that circuit output frequency is strictly and solely determined by the input voltage.

Start-up or input overdrive can cause the circuit's AC-coupled feedback to latch. If this occurs, C1's output goes low; C2, detecting this via the 2.7M/0.1 μ F lag, goes high. This lifts C1's positive input and grounds the negative input with Q7, initiating normal circuit action.

Figure 5 shows the circuit's power consumption versus frequency. Zero frequency current is just 15 μ A, increasing to only 26 μ A at 10kHz.

A detailed description of this circuit's operation appears in the August 1996 issue of *Linear Technology* magazine.

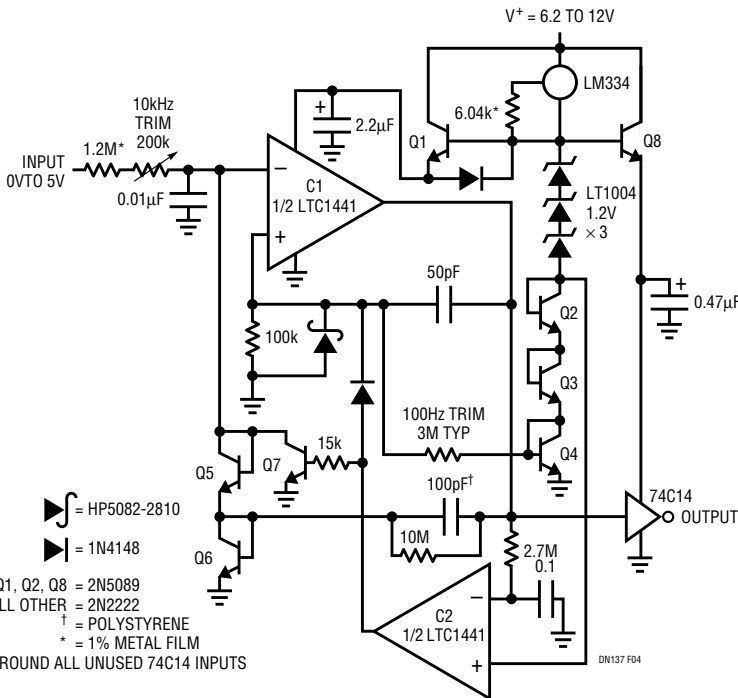

Figure 4. LTC1441-Based 0.02% V/F Converter Requires Only 26 μ A Supply Current

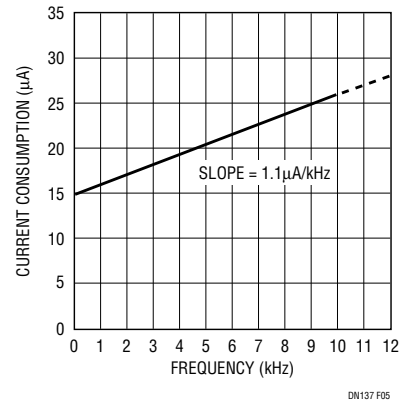

Figure 5. Current Consumption vs Frequency for the V-to-F Converter. Discharge Cycles Dominate 1.1 μ A/kHz Current Drain Increase

For literature on our Micropower Comparators, call **1-800-4-LINEAR**. For applications help, call (408) 432-1900, Ext. 2456